

# MO-BUTTERFLY

## mod. 700



### THREE FIXING METHODS

1- Operates discreetly without making any noise

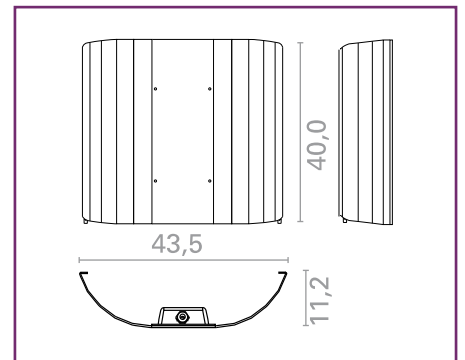

This electrical appliance was made in compliance with HACCP Directive Hazard Analysis Critical Control Points (CE 93/43-96/3-LD 155/97). The special UV-A lamps are positioned so as to attract all flying insects towards the appliance. When the insects approach, they become stuck to the adhesive paper which is supplied as a replacement item. This system allows the control and elimination of all flying insects in the surrounding area.

#### CONSTRUCTION AND INSTALLATION

MO-Butterfly is made completely from aluminium and is therefore designed for use in areas of food production. The adhesive paper is replaced in seconds allowing for easy and swift cleaning. The equipment can be installed on a front wall, back wall or on the ceiling.

#### LAMPS

Two high output UV-A lamps are supplied with a combined power rating of 30W and an operating range of about 10-12 metres.

#### SAFETY

The electrical part of the unit including the actinic UV lamps is completely insulated and protected by an unbreakable transparent cover to ensure maximum safety and maximum care for hygienic and sanitary standards. IP65 protection rating



| TECHNICAL SPECIFICATIONS |                    |
|--------------------------|--------------------|
| Dimensions in mm         | 112x435x400 mm (H) |
| Weight                   | 2.5 kg             |
| Voltage rating           | 230V/50HZ          |
| Total power consumption  | 40W                |
| UV-A lamps               | 2x15 W             |
| Material                 | Alluminium-PMMA    |
| Effective range          | 10-12 metres       |
| Protection level         | IP65               |
| Adhesive paper supply    | 34.5x17 cm         |

| SPARES |                            |
|--------|----------------------------|
| 0415   | 15W lamp                   |
| 002413 | pack of 10 adhesive papers |